

EMBEDDED GENERATION 30KW TO 5000KM

Version number 2 | Effective date: 4 January 2017

Introduction

This information pack has been developed under clause 5.3A of the National Electricity Rules (NER) to assist customers with the connection of their large scale generating units to Evoenergy's distribution network. The information pack only applies to those customers who are eligible to use clause 5.3A of the NER, broadly, where your generating unit has a nameplate rating greater than 30kW and less than 5000kW.

This information pack is designed to improve the clarity and transparency of the connection process and allow you to participate more effectively in this process. This information pack contains, but is not limited to, information to help you understand:

- the connection process and the requirements
- examples of relevant costs
- technical requirements relevant to the assessment of an *Application for Connection* including single line diagrams of our preferred connection arrangements, schematic diagrams of protection and control systems
- how to make a *Connection Enquiry* and an *Application for Connection* to our distribution network and
- model connection agreements

Evoenergy has a dedicated team who are here to guide and assist you through your connection project. For more information about the process of embedded generation connection, please contact Evoenergy:

Phone: **13 23 86**

Email: embeddedgeneration@evoenergy.com.au

The connection process

Embedded generation installations greater than 30kW and up to 5000kW will require connection to either the low voltage (415V) or high voltage distribution (11 and 22kV) network depending on the size and complexity of the connection.

The NER clause 5.3A.3 (b) 1 requires the customer to first make a connection enquiry to start the process. The Connection Process describes the process of making an enquiry and lodging an application to connect for an embedded generator.

A summary outline and the purpose of each stage of the connection process are further explained in this information pack and the Figure 1 below shows the stages and the steps associated with each stage.

Figure 1: Connection Process Diagram

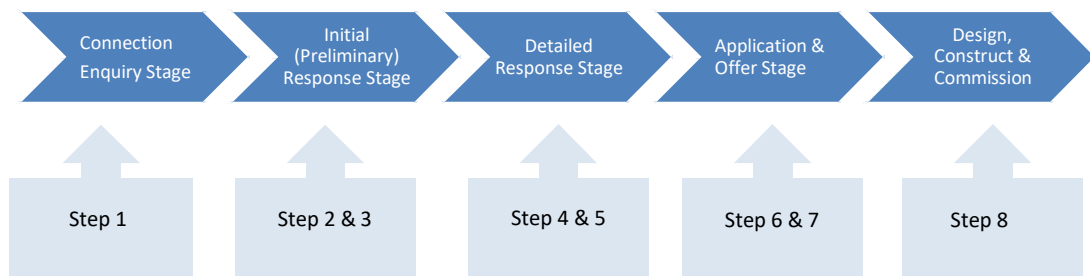

Step 1: Connection enquiry

The purpose of this stage is to advise Evoenergy of the customer's proposed connection requirements by submitting a completed *Special Connection Request Form (SCR)*. Connection types are categorised and presented on the Evoenergy web site and customers can select the type of connection suitable for their need (capacity).

The customer is advised that an undertaking of any detailed design or committing to expenditure, materials or resources is not required at this stage.

There is no charge involved when a customer makes the initial enquiry. The processes for enquiring and applying to Evoenergy for connection of an embedded generator are subject to the regulatory requirements detailed in National Electricity Rules (NER) Chapter 5A. See Clause 5.3 for more information.

Step 2: Initial response by Evoenergy

The purpose of this stage is to advise the customer about the availability of Evoenergy distribution network for the connection to the customer's facility and the next steps in the connection process to follow.

On receipt of the *Special Connection Request Form*, Evoenergy assesses the form for required information and advises the customer within 5 working days to provide additional

information if required. If sufficient information is available then Evoenergy provides the initial response within 5 working days.

Evoenergy's response will include advice on:

- the requirement of a *Preliminary Network Advice (PNA)* proposal, and
- the associated payment for the PNA

Evoenergy will send a *Quotation for work/Tax invoice* to the customer for this payment.

Step 3: Customer requests preliminary network advice

The purpose of this stage is to assess the available network connection options for the customer connection enquiry. To initiate this step the customer has to request Evoenergy to undertake an assessment of network. This requires a payment and the fee code for LV connection with class 2 to 5 is 571 and for HV connection fee code is 572. For further details refer to Electricity Network - Schedule of Charges found on our website evoenergy.com.au

A network alteration proposal will be undertaken by Evoenergy as soon as the customer confirms that the payment has been made against the invoice sent out with the initial response.

Evoenergy provides *Preliminary Network Advice* proposal to the customer after 10 working days of receipt of payment. This proposal discusses the available options and the preferred option for network connection. An indicative cost and the connection available by date for the preferred option is detailed in this proposal.

Step 4: Customer requests Network Technical Study

The purpose of this stage is to investigate the network connection option that the customer wishes to pursue.

Evoenergy is committed to connecting embedded generation to its network while also ensuring that the power supply to its customers is delivered in accordance with Evoenergy and industry safety and reliability standards. In order of importance, Evoenergy's prime directives are as follows:

1. The safety of personnel who work on the electricity network and to the general public.
2. To minimise asset loss of life, reduced performance and to prevent damage to electricity network assets.
3. To minimise disruption to all customers (quality of supply) inclusive of the applicant's site.

In order to investigate these aspects a *Network Technical Study* is to be undertaken. Evoenergy undertakes network technical studies up to 1500kW capacity. Above this capacity, Evoenergy requires customer to conduct studies by an engineering consultant.

Network Technical Study (NTS)

For large scale embedded generation installations (greater than 1500kW) that require connection to the high voltage (11kV) or the sub-transmission (132kV) network, the customer is required to have a *Network Technical Study* prepared by an engineering consultant with relevant knowledge, expertise and experience.

The scope of the Network Technical Study			
1	Assess the performance of the proposed large scale embedded generation installation and the impact of the connection to the Evoenergy network against the technical requirements listed under clause S5.2.5 of the <i>National Electricity Rules</i> (NER),		
2	Formulate appropriate access standards for the connection		
3	Provide adequate supporting information in the form of computer simulations and calculations to demonstrate compliance with the NER, technical requirements and proposed access standards		
4	Evaluate inverters with an individual rating of greater than 30kW as outlined below		
5	The study must include, but should not be limited to the following:	The development of network models,	
		Steady state and dynamic load flow studies,	
		A fault level study,	
		Harmonics and voltage flicker and fluctuation studies,	
		Equipment ratings,	
		Network augmentation and modification requirements,	
		Protection, supervisory control and data acquisition (SCADA) and communication and metering requirements,	Protection requirements (main and backup), including but not limited to: <ul style="list-style-type: none"> • anti-islanding, • over/under voltage and frequency, • neutral voltage displacement, • overcurrent and earthfault, • negative sequence voltage and current, • synchronisation, and • intertrip.
			SCADA for control and monitoring,
			Effects on existing protection settings, such as zone substations,
	Communication system to comply with existing Evoenergy system,		

			Metering to comply with National Electricity Market (NEM) requirements,
		Evaluation of inverters > 30kW must include, but not be limited to the following	A review of Australian standard AS4777 and determination of how the principles of this standard can be applied to larger systems and the requirements for larger inverters
			An evaluation and assessment of the power electronics and associated circuitry used to achieve the protection and SCADA functions
			Testing standards which include the method of testing and expected results, such as: <ul style="list-style-type: none"> • inverter – type tests and routine tests, • protection tests, • performance tests, • periodic tests, • power factor tests, • harmonic current limit tests, • transient voltage limit tests, and • quality of supply tests.
			An evaluation of the required level of safety and performance of the inverter including, control of real and reactive power and the circuitry used, the power factor, performance degradation over time and lifetime expectancy
			Inverter data, such as impedances, fault levels and ratings required for network technical studies
			A risk assessment, including type and failure modes, the probability of failure, impact on personnel and public safety, network assets and quality of supply
			Information on Australian and overseas experience (safety and operational) with a particular inverter, including details of where it was installed and operational
			Evidence of communication with TransGrid, including the expected impact on the network and their requirements. This is required for connections to the 132kV network
			Evidence of communication with Australian Energy Market Operator (AEMO) and their requirements

			Project timelines
			The required augmentation or modification to Evoenergy network
6	Evidence of communication with TransGrid, including the expected impact on the network and their requirements. This is required for connections to the 132kV network,		
7	Evidence of communication with Australian Energy Market Operator (AEMO) and their requirements,		
8	Project timelines, and		
9	The required augmentation or modification to Evoenergy network.		

Provision of Evoenergy data

Evoenergy will cooperate with the customer's engineering consultant in their preparation of the *Network Technical Study* and provide relevant network data in a timely manner to enable the study to be conducted. Information may include equipment ratings, impedances, fault levels and asset locations.

Costs

The customer is required to pay the network charge for the *Network Technical Study* if conducted by Evoenergy or the network charge for provision of network data and review of the study report. The charge for *Network Technical Study* depends on the type (LV or HV) and the class of the connection.

Refer to the Table below for relevant fee code and for further details refer to Electricity Network - Schedule of Charges on our website evoenergy.com.au

Class of the Connection	Code for HV	Code for LV
Class 1	NA	574
Class 2		575
Class 3		576
Class 4		577
Class 5	579	578
Provision of Data & Review	573	573

This is a standard fee and if this amount is exceeded due to the complexity of the connection and additional activities, Evoenergy will advise the customer about the increase in the fee. Evoenergy will apply an hourly rate for additional work.

Step 5: Evoenergy reviews NTS and provides Preliminary Connection Proposal

The purpose of this stage is for Evoenergy to review the outcome of the technical studies and determine the basis for Evoenergy's preparation of a *Preliminary Connection Proposal* to connect the customer.

A *Preliminary Connection Proposal* to connect will be prepared by Evoenergy and includes the following:

- Advice on the maximum embedded generation capacity and the details of the connection arrangement that can be accepted at the proposed location.
- Details of the network augmentation or modification required to enable the proposed connection.
- A schedule of itemised estimated costs to be funded by the customer, including network augmentation or modification costs if required.
- A program of works to complete the connection, including augmentation or modification work, if required.
- Applicable service standards.

Preliminary Connection Proposal further includes an invitation to the customer to make an official connection application.

Step 6: Customer to provide Application for Connection

The purpose of this stage is to receive a formal *Application for Connection* form by the customer and process the application further to prepare an offer. Both the customer and Evoenergy have to determine a suitable connection option and ascertain that all technical requirements are met.

Upon receiving the *Preliminary Connection Proposal* to connect, the customer can decide if the connection conditions are acceptable and if so, the customer will lodge the formal *Application for Connection* to the network in accordance with the Electricity Network Capital Contribution Code found on evoenergy.com.au

Receipt of Application for Connection

On receipt of the *Application for Connection*, Evoenergy assess the application for required information and advise the customer within 10 days to provide additional information as required.

At minimum, the following information is required to process the application:

- Final version of NTS and other technical study reports which are accepted by Evoenergy, AEMO and TransGrid and other entities as required.
- Planning Approval documentation from EPD & TAMS.

A standard *Application for Connection Form* is available on the website and will require additional information in comparison with the standard *Enquiry Form* submitted.

Step 7: Evoenergy provides an Offer to Connect and a draft Grid Connection Agreement (GCA)

The purpose of this step is to make an *Offer* to the customer.

If the customer decides to proceed with the *Offer* then customer will be required to enter into a contract.

Step 8: Design, Construction and Commissioning

Design

Evoenergy will undertake detailed design of *Connection Assets* after the signing of the agreement and meeting the necessary requirements. A project manager will be appointed depending on the size of the project and liaise with the customer's principal contractor. Procurement of long lead equipment will be undertaken at this stage after the detailed designs and specifications have been approved.

Construction

The customer's principal contractor and the Evoenergy project manager will coordinate the joint works during construction stage including the handovers, testing and commissioning activities in accordance with the schedules in the agreement.

Metering

Evoenergy is a metering service provider and if required customer can choose Evoenergy to be the preferred metering service provider. The customer's installer can submit a *Request for Service* form to Evoenergy for an appointment to install metering. The installer can submit this form at any time after the *Offer to Connect* has been received by the customer. It is at this point Evoenergy becomes aware that the embedded generation installation is proceeding to completion and that the customer will require a new meter. Evoenergy will arrange a suitable appointment date with the installer to carry out this work.

Evoenergy will meet the customer's installer on-site to install a second electricity meter or replace the existing meter. Evoenergy will only install the meter and connect the embedded generation system to the network once steps 1 to 8, as set out in this document, have been completed.

EPD and other Authority Notification

The customer's principal contractor or installers are responsible to advise EPD that the installation is complete and ready for inspection by submitting a request for *Certificate of Electrical Safety*.

EPD will carry out an inspection of the wiring and other electrical work. If the installation passes the inspection, EPD will place an approval sticker adjacent to the existing metering installation or in the meter panel.

Commissioning

The customer's principal contractor or the installer is responsible to submit detailed commissioning instructions to Evoenergy for approval. The instructions must include testing of all protection schemes (main and backup), control systems (SCADA) and all inverter protection and safety features. Once approval has been granted by Evoenergy, the installer must give Evoenergy at least two weeks' notice to enable Evoenergy personnel to witness the testing. Following the successful commissioning of the installation, certified copies of the test results must be provided to Evoenergy.

The NER clause 5.3A.3 (b) requires the Information Pack to include following:

NER Requirement	Description
5.3A.3(b)(2)	Single line diagrams of the DNSPs preferred connection arrangements and other possible connection. Agreements for integration of an embedded generating unit, showing the connection point, the point of common coupling, the embedded generating unit(s), load(s), meter(s), circuit breaker and isolator(s).

Evoenergy's preferred connection arrangements are shown below:

1. Direct Connection to shared or dedicated 11kV Feeder

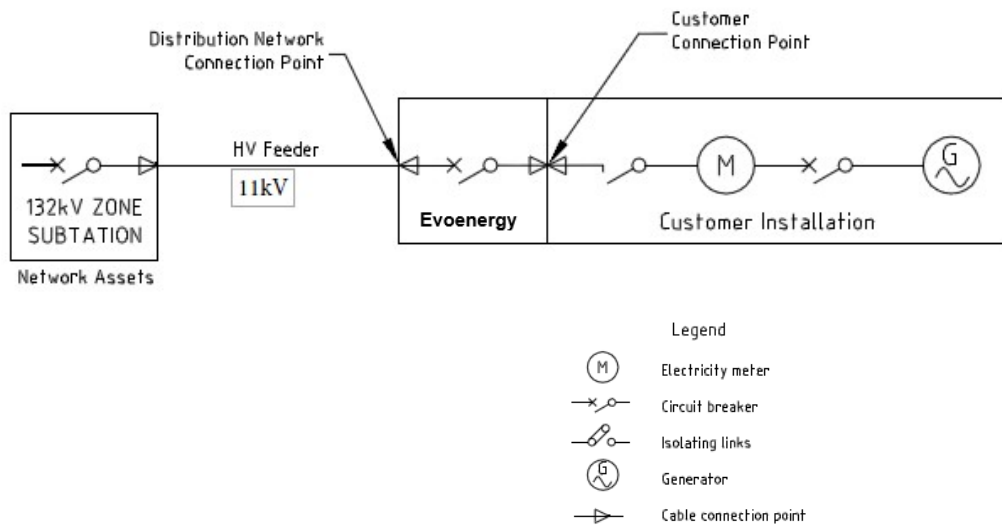

2. Direct Connection to 415V Network via the distribution transformer

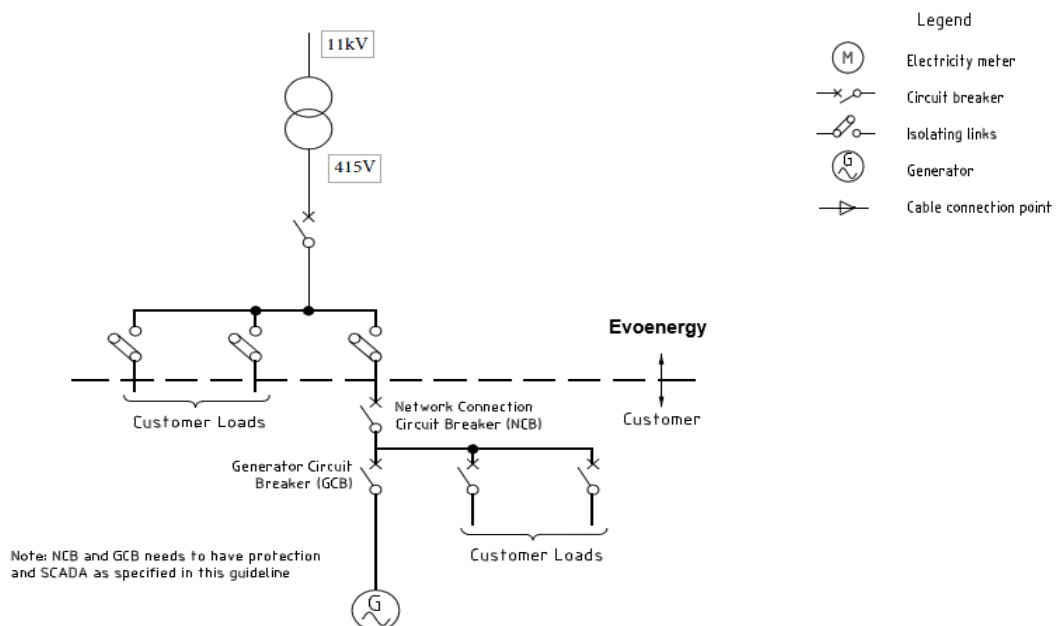

5.3A.3(b)(2)	<p>Purpose of this Clause is to provide information and a sample schematic diagram of the protection system relevant to the connection of an embedded generating unit to the distribution network, showing the protection system and control system, including all relevant current circuits, relay potential circuits, alarm and monitoring circuits, back-up systems and parameters of protection and control system elements.</p> <p>Refer to section (7) of the Requirements for Connection of Embedded Generators up to 5MW to the Evoenergy's Distribution network found on evoenergy.com.au</p>																											
5.3A.3(b)(4)	<p>Worked examples of connection service charges, enquiry and application fees for the connection of embedded generating units, based on the preferred and possible connection arrangements set out in paragraph (b)(2). Charges shown below have been based on the possible connection arrangements and indicative.</p> <p>Note that charges will be determined in accordance with the regulatory requirements prevailing at the time. Refer to Electricity Network – Schedule of Charges for specific cost codes relevant to the fees as shown below found on evoenergy.com.au</p> <table border="1" data-bbox="454 712 1458 1153"> <thead> <tr> <th data-bbox="454 712 746 741">Single Line Diagram</th> <th data-bbox="746 712 1027 741">Type of Fee</th> <th data-bbox="1027 712 1458 741">Cost</th> </tr> </thead> <tbody> <tr> <td data-bbox="454 741 746 936">1</td> <td data-bbox="746 741 1027 770">Connection Enquiry</td> <td data-bbox="1027 741 1458 770">\$1,132 or Code 572</td> </tr> <tr> <td data-bbox="454 770 746 824"></td> <td data-bbox="746 770 1027 824">Preliminary Works Arrangement Fee</td> <td data-bbox="1027 770 1458 824">\$49,875 and varies</td> </tr> <tr> <td data-bbox="454 824 746 878"></td> <td data-bbox="746 824 1027 878">Network Charges (per annum)*</td> <td data-bbox="1027 824 1458 878">\$10,000 and varies</td> </tr> <tr> <td colspan="3" data-bbox="454 878 1458 936">*Charges based on Single Line Diagram 1 and assumed connection voltage level of 11 kV for a 4.5MW system</td> </tr> <tr> <td data-bbox="454 936 746 1019">2</td> <td data-bbox="746 936 1027 965">Connection Enquiry</td> <td data-bbox="1027 936 1458 965">\$566 or Code 571</td> </tr> <tr> <td data-bbox="454 965 746 1019"></td> <td data-bbox="746 965 1027 1019">Preliminary Works</td> <td data-bbox="1027 965 1458 1019">\$15,000 and varies</td> </tr> <tr> <td data-bbox="454 1019 746 1075"></td> <td data-bbox="746 1019 1027 1075">Network Charges (per annum)*</td> <td data-bbox="1027 1019 1458 1075">TBA</td> </tr> <tr> <td colspan="3" data-bbox="454 1075 1458 1153">*Charges based on Single Line Diagram 2 and assumed connection voltage level of 415V for a 1MW system</td> </tr> </tbody> </table>	Single Line Diagram	Type of Fee	Cost	1	Connection Enquiry	\$1,132 or Code 572		Preliminary Works Arrangement Fee	\$49,875 and varies		Network Charges (per annum)*	\$10,000 and varies	*Charges based on Single Line Diagram 1 and assumed connection voltage level of 11 kV for a 4.5MW system			2	Connection Enquiry	\$566 or Code 571		Preliminary Works	\$15,000 and varies		Network Charges (per annum)*	TBA	*Charges based on Single Line Diagram 2 and assumed connection voltage level of 415V for a 1MW system		
Single Line Diagram	Type of Fee	Cost																										
1	Connection Enquiry	\$1,132 or Code 572																										
	Preliminary Works Arrangement Fee	\$49,875 and varies																										
	Network Charges (per annum)*	\$10,000 and varies																										
*Charges based on Single Line Diagram 1 and assumed connection voltage level of 11 kV for a 4.5MW system																												
2	Connection Enquiry	\$566 or Code 571																										
	Preliminary Works	\$15,000 and varies																										
	Network Charges (per annum)*	TBA																										
*Charges based on Single Line Diagram 2 and assumed connection voltage level of 415V for a 1MW system																												
5.3A.3(b)(5)	<p>Details of any minimum access standards or plant standards the Distribution Network Service Provider considers are applicable to embedded generating units and generating units.</p> <p>Information relating to Access Standards can be found in Technical performance requirements for the connection of large scale embedded generators to Evoenergy's network found on evoenergy.com.au</p>																											
5.3A.3(b)(6)	<p>Technical requirements relevant to the process of a Connection Enquiry or an Application to Connect, including information of the type, but not limited to:</p> <ul style="list-style-type: none"> (i) protection systems and protection schemes; (ii) fault level management principles; (iii) reactive power capability and power factor correction; (iv) power quality and how limits are allocated; (v) responses to frequency and voltage disturbances; (vi) voltage control and regulation; (vii) remote monitoring equipment, control and communication requirements; (viii) earthing requirements and other relevant safety requirements (ix) circumstances in which augmentation may be required to facilitate integration of an embedded generating unit into the network; and (x) commissioning and testing requirements <p>Refer to Technical performance requirements for the connection of large scale embedded generators to Evoenergy's network found on evoenergy.com.au</p>																											