

EVOENERGY LOW VOLTAGE (LV) POINT OF ENTRY (POE) CUBICLE REQUIREMENTS

GUIDELINES ON THE MANUFACTURE, SERVICING, EARTHING AND BONDING ARRANGEMENTS FOR LOW VOLTAGE (LV) POINT OF ENTRY CUBICLES (POE) SERVICED BY EVOENERGY NETWORK SERVICE CABLES FOR NON-DOMESTIC, COMMERCIAL, MULTI-RESIDENTIAL OR INDUSTRIAL INSTALLATIONS

This document stipulates Evoenergy requirements for POE cubicles

CONTENTS

1. INTRODUCTION	4	4. EVOENERGY POINT OF ENTRY (POE) APPROVALS	9
1.1 Scope	4	4.1 Switchboard Plan Approval Process	9
1.2 Purpose	4	4.2 Supply of Meter Protection Devices (Fuse Holders)	10
1.3 Earthing Arrangement Terminology	4	4.3 Supply of Network Connection Equipment	10
1.3.1 TN Network	5	5. GENERAL NOTES ON POE CUBICLES	10
1.3.2 TN-C-S system of Earthing	5	6. REFERENCE TO DRAWINGS	10
1.3.3 Multiple MEN Links contained within the One Building Structure	5	7. DEFINITIONS AND ABBREVIATIONS	11
1.3.4 Combination POE MSB Switchboards	5	VERSION CONTROL	12
2. EVOENERGY POINT OF ENTRY (POE) REQUIREMENTS	7	DOCUMENT CONTROL	12
2.1 Evoenergy POE Neutral Link	7	APPENDIX A – POE MEN LINK & POE MAIN EARTH CABLE SIZES	13
2.2 POE MEN Link	7	APPENDIX B – METHOD 1 SCHEMATIC	14
2.3 POE Earth Link	7	APPENDIX C – METHOD 2 SCHEMATIC	15
2.4 Evoenergy Earth Chassis Bond:	7	APPENDIX D – METHOD 3 SCHEMATIC	16
2.5 Fastening of POE Earth and Neutral Links	7	APPENDIX E – METHOD 4 SCHEMATIC	17
2.6 POE Earthing Electrode and Earth Cable	7		
2.7 POE Cubicles and Multiple MEN Link	8		
3. POE EARTHING CONNECTION METHODS	8		
3.1 Method 1	8		
3.2 Method 2	8		
3.3 Method 3	9		
3.4 Method 4	9		

Disclaimer

Whilst this document contains material relevant to the electricity industry legislation, codes of practice and standards, it is not intended to provide legal advice on how electrical contractors can meet their own statutory obligations or comply with legislation, codes of practice or industry standards such as AS/NZS 3000 (Wiring Rules). Whilst care has been taken in the preparation of this document, Evoenergy does not guarantee that the information contained in this document is accurate, complete or up to date at time of publication. To the extent permitted by the relevant legislation Evoenergy will not be responsible for any loss, damage, cost or expense incurred as a result of any error, omission or misrepresentation in relation to the information contained in this document.

Note

Printed versions of this document are “uncontrolled copies” - the latest version is available on the Evoenergy website.

Copyright

Copyright© 2018 Evoenergy. This publication is copyright. Except as permitted under the Copyright Act 1968 no part of this publication may be reproduced by any process without the specific written permission of the copyright owner. All rights reserved.

1. INTRODUCTION

1.1 Scope

The scope of this document is to provide guidelines on the manufacture, servicing, earthing and bonding arrangements for Low voltage (LV) point of entry cubicles (POE) serviced by Evoenergy network service cables for non-domestic commercial multi-residential or industrial installations. The wiring methods used in this document are based on the MEN system of earthing as stated by the IEC definitions of TNCS which are contained within the AS/NZS 3000.

This document covers the following aspects:

- Servicing of POE cubicles;
- POE neutral links;
- POE MEN links;
- POE earthing links;
- POE earthing conductors;
- POE earth chassis bonding conductor;
- POE earth stake.

This document provides guidance to the use of the above mentioned equipment in order to provide a suitable and safe fault path for the incoming Evoenergy network cables whilst managing the earth potential rise on the POE chassis during a fault event.

This document needs to be read in conjunction with Evoenergy Service and Installation Rules.

1.2 Purpose

The purpose of this document is to provide guidance to avoid the potentially hazardous situations of parallel neutral paths or circulating neutral currents occurring within the customers building(s). The situation is applicable when the POE cubicle is connected to/within arm's reach of:

- The MSB; or
- The building containing the MSB

This document stipulates Evoenergy requirements for POE cubicles.

The chances of the hazard occurring is increased if the two switchboards are within arm's reach of each other or the building is constructed of conductive materials, such as reinforced concrete, a metallic frame, copper water pipes, overhead metallic walk ways or the use of a metal facade (such as Aluminium cladding panels).

This document is intended to be used by POE cubicle manufacturers, contractors installing the POE cubicles, the personnel connecting the POE cubicles to the network, and for the service and installation officers for checking compliance.

1.3 Earthing Arrangement Terminology

Three types of earthing arrangements are defined in clause 5.1.3 of AS/NZS 3000 (International Standard IEC 60364), having a two letter code, namely 'TN', 'TT', and 'IT'.

The first letter pertains to the connection between the earth and the power supply equipment:

“**T**” – direct connection of a point with earth

“**I**” – no point is connected with earth (isolation), except perhaps via high impedance.

The second letter pertains to the connection between earth and the electrical device(s) which are being supplied:

“**T**” – direct connection of a point with earth

“**N**” – direct connection to neutral at the origin of installation, which is connecting to earth.

1.3.1 TN Network

In TN type of earthing system, the star point of a three phase supply (generator or transformer) is connected to earth. The conductive metallic chassis of the supply and the connected electrical devices are connected to earth via this earth point on the source side¹.

1.3.2 TN-C-S system of Earthing

In this type of earthing system, part of the earthing system uses a combined Protective Earth Neutral conductor PEN conductor for earthing, whereas for the remaining downstream part of the system uses separate conductors for both the Protective Earth (PE) and for the Neutral (N). Usually, the combined PEN conductor is used near the source of the system.

FIGURE 1. IEC TNCS SYSTEM OF EARTHING (MEN)

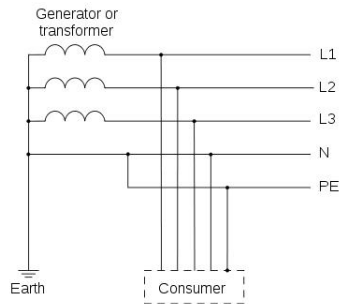

1.3.3 Multiple MEN Links contained within the One Building Structure

Under the MEN system of earthing, the earthing system from one MEN link should not connect with the earthing system from another MEN link where both links are fed from the same point of supply (distribution transformer). If the earthing systems do mix the pillar/cubicle/switchboard further up the distribution line will contain the MEN link and the earth stake and it will feed the other downstream switchboard directly with an earth wire without a MEN link and without an earth stake².

1.3.4 Combination POE MSB Switchboards

Evoenergy require a single MEN link inside a combination POE Main switchboard. This is to avoid having circulating neutral currents within the switchboard chassis itself and circulating within the earthing conductors within the combined switchboard.

In a combination POE/MSB with one common switchboard chassis serviced by an incoming Evoenergy cables, the MEN can be performed within the customer section as long as method 3 (refer to Appendix D) can be achieved.

¹ Refer to figure 1: IEC TNCS System of Earthing (MEN)

² Refer to figure 2: the MEN system of earthing on a LV circuit from a distribution substation

FIGURE 2. THE MEN SYSTEM OF EARTHING ON A LOW VOLTAGE CIRCUIT FROM A DISTRIBUTION SUBSTATION DISPLAYING MULTIPLE DIFFERENT INSTALLATIONS USING POE CUBICLES³

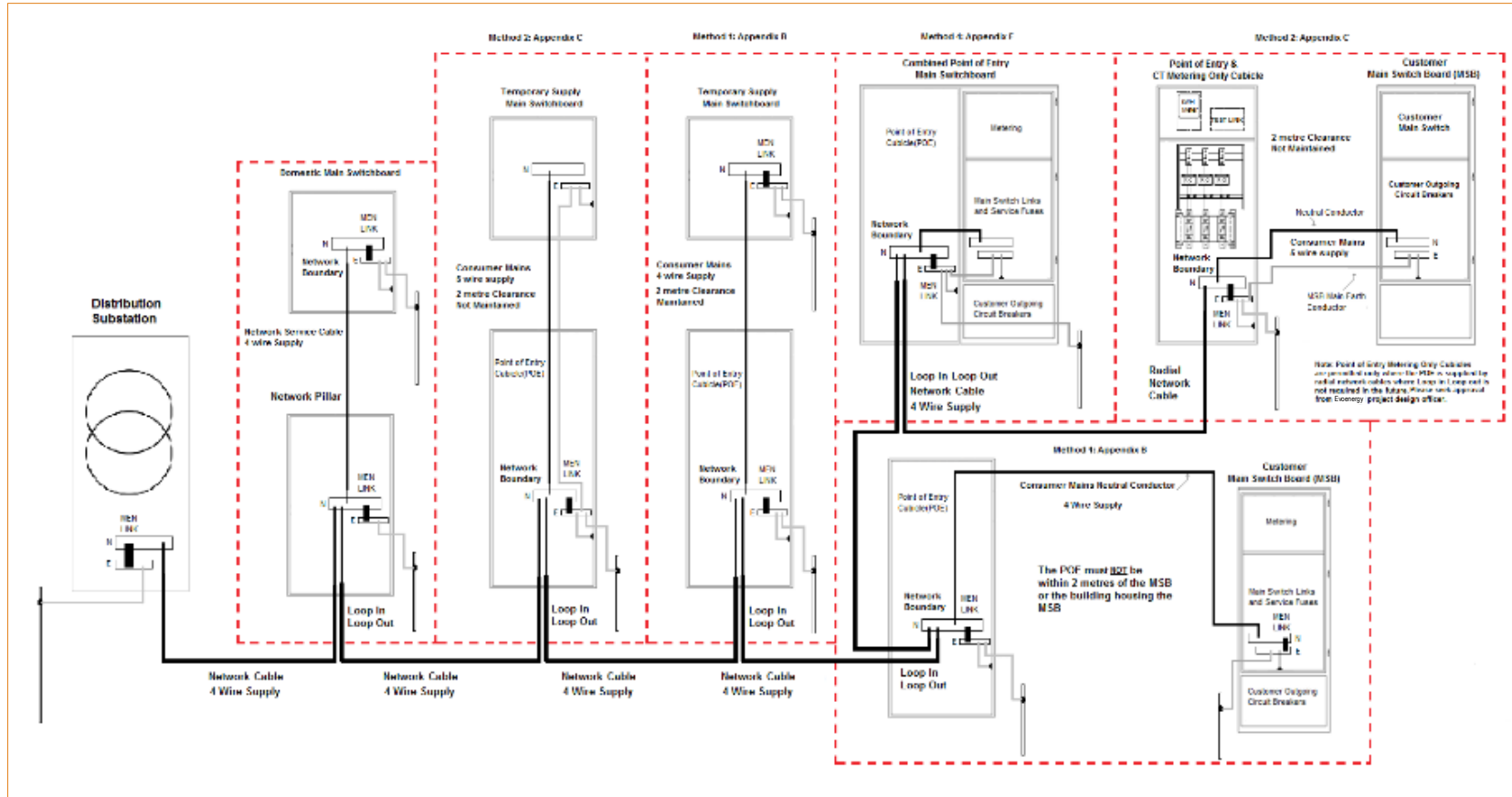

³ Note: This sketch and all Customer's metering arrangements are indicative and for information only. C.T. Metering is not permitted within the Point of Entry section of the Cubicle.

2. EVOENERGY POINT OF ENTRY (POE) REQUIREMENTS

This section outlines the neutral and earthing requirements of a POE that is connected to Evoenergy's electrical network. These requirements cover free standing POE cubicles and combination POE/MSB cubicles.

2.1 Evoenergy POE Neutral Link

On all POE cubicles serviced by Evoenergy network cables, Evoenergy requires a tinned copper neutral bar that is adequately rated and sized to terminate the lug(s) of the aluminium neutral conductor(s), as per relevant drawing 8913-213-06 or 8913-213-08

Note 1: Point of Entry cubicles are often used to service other installations, via a Weber fuse way strip, in such cases the POE neutral link must be suitable to accommodate the outgoing neutral conductor termination using lug(s) as well as the incoming neutral conductor termination using lug.

Note 2: If the POE cubicle is serviced by parallel network cables, the POE neutral link must be able to accommodate both parallel neutral conductor lug(s).

2.2 POE MEN Link

On all POE cubicles serviced by an Evoenergy network cable, Evoenergy requires a POE MEN link adequately rated and sized to the incoming network cable(s), refer to table 3 for details. For example if the incoming network service cable is a 240mm² Aluminium cable, the POE MEN link must be a minimum of 70mm² copper.

2.3 POE Earth Link

On all POE cubicles serviced by an Evoenergy network cable Evoenergy requires a dedicated tinned copper POE earth bar or earth link. The POE earth bar/link must have a minimum of four separate terminal holes to terminate the POE earth cable, the POE MEN link, the Earth Link Chassis Bond and the MSB earth cable separately.

2.4 Evoenergy Earth Chassis Bond:

The Evoenergy Earth chassis bond will provide a suitable connection of the earth link to the POE metal chassis without dropping in cross sectional area as it connects directly to the bare metal chassis. The earth chassis bond must be capable of carrying a minimum fault current of 30,000 A without suffering any damage.

If the earth chassis bond connects to an earth stud or earth bracket it shall be fully welded to the main part of the chassis around the full circumference of a stud or on all sides of a bracket.

Spot or tack welds on earthing points are **NOT** acceptable.

Note 1: The Evoenergy earth chassis bond is required on all switchboards that contain Evoenergy assets (network cables and/or switchgear equipment) and or contains consumer mains cables.

2.5 Fastening of POE Earth and Neutral Links

The POE Earth and Neutral links must be fastened to the POE chassis to withstand the magnetic forces of fault current without suffering any damage. POE Earth links screwed to a POE chassis with self-drilling tech screws is not an acceptable method of fastening the links.

2.6 POE Earthing Electrode and Earth Cable

On all POE cubicles fed by an Evoenergy network cable, the cubicle shall have access to a local POE earth stake via an earth cable having the same size as the POE MEN Link⁴ refer to table 3 for sizes. The Earth electrode shall be of the same cross-sectional area as the earth cable connecting to it. A bare earth conductor may be used as the electrode provided that it is sized as per table 3, in ground

⁴ Refer to Appendix A: POE MEN Link & POE Main Earth Cable Sizes

photos shall be available on request if bare earth electrode is used. A round U bolt clamp should be used to fasten the earth cable to the earthing electrode.

2.7 POE Cubicles and Multiple MEN Link

If a freestanding POE cubicle is located up against or within two (2) metres of any building structure connected to the building MSB, Evoenergy will **only** connect supply if there is only one MEN contained within the building, and the MEN link and main earth stake are located within and local to the POE cubicle as per the MEN system of earthing⁵.

3. POE EARTHING CONNECTION METHODS

One of the POE earthing methods outlined below must be followed to ensure that the POE cubicle is correctly earthed in accordance with AS/NZS 3000 and Evoenergy Service and Installation Rules.

3.1 Method 1

Free Standing Point of Entry (POE) Cubicle and remote MSB configured as outbuildings having a POE MEN with Earth Stake and MSB MEN with Earth Stake

- This is the Evoenergy preferred method of connection.
- This method is suitable to be used only where there is an adequate clearance available between the POE and the MSB.
- The POE cubicle shall not be within two (2) metres of any building connected to the main switch board or the main switchboard.
- With this method, the POE and MSB have their separate MEN links and Earth Stakes.
- This method is the preferred method where there is a long distance between the POE and MSB in the interests of decreasing the fault loop impedance and the earth potential rise at the MSB during a fault event.
- This method is also preferred where the customer's MSB is closer to the distribution substation than the POE cubicle.
- Refer to Appendix B – Method 1 Schematic.

3.2 Method 2

Free Standing Point of Entry (POE) cubicle containing the main building MEN link and main building earth stake

- This method must be used if the POE cubicle is installed up against or within two (2) metres of a building or connected to the installations MSB and when adequate separation between the POE cubicle and the MSB or the building containing the MSB is not achievable.
- There shall be only one MEN link per building and it shall be labelled appropriately.
- The POE MEN link is to remain intact inside the POE cubicle along with the connection of the POE earth cable (that connects to the POE earth stake).
- An adequately sized and rated earth conductor shall be installed between the respective POE and the MSB earth links.
- The MSB will not have a MEN link and it will not have an earth stake.
- This earthing method and location of the MEN is considered compliant to AS/NZS 3000:2007 Clause 5.3.5.1 Exceptions 2 & 3.
- If a full size earth is not used, this installation method increases the fault loop impedance for a fault that occurs inside the customers MSB. Consideration must be given to length of consumer mains in such installations.

⁵ Refer to Appendix C: Method 2 Schematic

- Refer to Clause 5.7 and calculation B5.2.2 of AS/NZS 3000:2007 wiring rules for the maximum lengths of the consumer mains in particular when using this method of installation.
- Refer to Appendix C – Method 2 Schematic.

Note: Calculation B5.2.2 is only considered valid for cables up to 120mm² CSA;

3.3 Method 3

Combined Point of Entry (POE) Cubicle and MSB with neutral and earth links common to the POE and customer cubicles, the MEN can be performed inside the customer cubicle

- In this option the neutral bar/link and earth bar/link is common to both the POE cubicle and the customer MSB cubicle.
- The MEN link and main earth is performed inside the customer cubicle next to the POE cubicle.
- The MEN link and the main earth cables are sized to Table 3 in Appendix A.
- The MEN Link must be easily identifiable and readily accessible to Evoenergy staff.
- The MEN link shall be performed inside the customer part of the switchboard. The chassis earth bond (if applicable) and the main earth cable must be terminated in close proximity to the MEN link with no joints in both the common earth busbar and the common neutral busbar. All cables should terminate as close as possible to each other. (No cables are to be used for connections between busbars).
- Refer to Appendix D – Method 3 Schematic.

3.4 Method 4

Combined Point of Entry (POE) Cubicle and MSB with MEN link and main earth terminals contained within the POE cubicle

- Evoenergy will allow the MEN link to be housed inside the POE cubicle behind the Evoenergy lock and not inside the customer part of the switchboard.
- Refer to Appendix E – Method 4 Schematic.

4. EVOENERGY POINT OF ENTRY (POE) APPROVALS

Evoenergy has introduced a new improvement initiative – **Electronic Point of Entry (POE) drawing approval process**. Some important things to note for electronic approval process:

- The POE drawings (free standing or combined POE/Main Switchboard (MSB)) are required to be in pdf format
- The POE drawings must be sent to Service & Installation Officer via email: poedrawingapproval@evoenergy.com.au
- The POE drawing must have relevant information in the “project details” area such as –
 - Evoenergy Project Number
 - Suburb, Block & Section
 - Customer’s details

Evoenergy will review & return the stamped drawings in pdf formats by email within 10 business days. Evoenergy’s response email will be sent to the requester and all other parties CCed in the request email.

4.1 Switchboard Plan Approval Process

Evoenergy will no longer be conducting plan approvals for anything past the network boundary point. This means that the only items that shall be approved are Point of Entry (PoE) Cubicles (or similar). The approval of these drawings shall be limited to the area housing Evoenergy equipment only and not cover any items that are also provided on the drawing.

The reason for this change is that the areas past this network boundary point are required to meet Australian Standards and are not covered by any Evoenergy Rules or Standards.

4.2 Supply of Meter Protection Devices (Fuse Holders)

Evoenergy will no longer issue meter protection devices (MPD's) to any external company. In most cases the devices provided are in the form of a fuse holder and are manufactured into multi-tenant meter panels.

The reason for this change is that the area past the network boundary point are required to meet Australian Standards and the type of meter protection device required is not covered by any Evoenergy Rules or Standards. It is noted that reference to a stand-alone Meter Protection Device is within the PO07173 "Evoenergy Service and Installation Rules", however the type of device cannot be specified by Evoenergy.

4.3 Supply of Network Connection Equipment

Evoenergy will no longer issue the network connection equipment such as 400A or 630A Holec Fuse Link Carriers to switchboard manufacturers. However, the Point of Entry (POE) cubicle/switchboard must have pre-drilled base plate along with PVC Holec fuse dividers for Evoenergy to install the Holec Carriers under the network connection work.

Evoenergy will continue issuing the 2000A isolator to switchboard manufacturers, however, this will be only issued under the relevant customer initiated project with approval of relevant project engineer. Switchboard manufacturer will need to seek the project engineer's contact details from their customer/Electrical Contractor and contact the relevant project engineer and coordinate the equipment pick up from Evoenergy supply centre at Greenway.

The POE cubicle must comply with PO07173 "Evoenergy Service and Installation Rules" and relevant Evoenergy Standard drawing either 8913-213-06 or 8913-213-08 specified under the connection agreement.

Please feel free to send your comments, feedback or improvement suggestions to poedrawingapproval@evoenergy.com.au.

5. GENERAL NOTES ON POE CUBICLES

All POE cubicles and switchboards containing Evoenergy assets must be sealed from the ingress of moisture and vermin; including all incoming conduits.

No holes shall be permitted in the PoE without approval from Evoenergy and the manufacturer is to certify the IP and KA rating of the PoE with any additional holes.

6. REFERENCE TO DRAWINGS

Evoenergy documents	
Document number	Document title
PO07173	Service and Installation rules
Evoenergy drawings	
Document number	Document title
8911 – 313	Non Domestic – Small Installation POE/Meter Box for Installation with Underground Service Cables up to 50mm ² Cu
8911 – 324	Typical Metering Cubicle for Multi-Installation and Looping or Paralleling of Evoenergy Cables
8913 – 213 – 06	P.O.E. 315A to 630A Free Standing or Wall Mounted with Modular Feeder Units
8913 – 213 – 08	P.O.E. Radial Service Cubicle 800A to 2000A Free Standing or Wall Mounted

Australian Standards	
Document number	Document title
AS/ NZS 3000	Electrical Installations
IEC 60364	Low-voltage electrical installations

7. DEFINITIONS AND ABBREVIATIONS

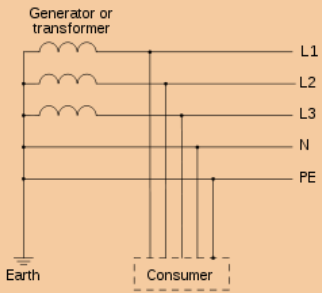
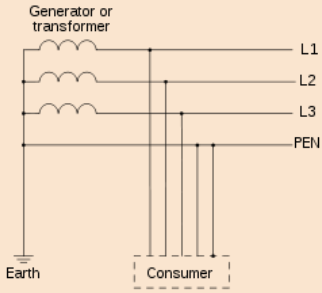
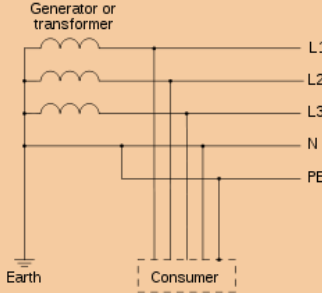
TERM	DEFINITION
LV	Low Voltage
MEN	Multiple Earthed Neutral
MSB	Main Switch Board
PE	Protective Earth
POE	Point of Entry
TN-S	 <p>N and PE are separate conductors which are only connected at the source of supply (i.e. generator or transformer).</p>
TN-C	 <p>N and PE conductors are combined to form PEN.</p>
TN-C-S (MEN system of earthing)	 <p>N and PE conductors are combined at source of supply (i.e. generator or transformer) to the building distribution point, and then split into PE and N conductors in fixed indoor wiring and flexible power cords.</p>

VERSION CONTROL

VERSION	DETAILS	APPROVED
1.0	Initial Document	24 November 2015;
2.0	Converted to Project 201 Template	28 September 2017;
3.0	Re-branded to Evoenergy	16 January 2018;
4.0	Disclaimer and Copyright notes added. References Amended. Appendix A Amended. Appendix E Removed.	08 January 2019;
4.1	Converted on new Template; Chapter 4 added; Appendix A, D & E Modified	Brett North; Nadeem Azizi; Wayne Cleland; 23 July 2020

DOCUMENT CONTROL

DOCUMENT OWNER	PUBLISH DATE	REVIEW DATE
Asset Standards	23/07/2020	23/07/2022

APPENDIX A – POE MEN LINK & POE MAIN EARTH CABLE SIZES

INCOMING NETWORK CABLE SIZE mm ²	MINIMUM POE MEN LINK SIZE mm ²	MINIMUM POE EARTH CABLE SIZE mm ²	MINIMUM POE EARTH LINK CHASSIS BOND SIZE mm ²
1 x 16mm ² Copper (multi-core)	70mm ² Copper	70mm ² Copper	70mm ² Copper
1 x 35mm ² Copper (multi-core)	70mm ² Copper	70mm ² Copper	70mm ² Copper
1 x 50mm ² Copper (multi-core)	70mm ² Copper	70mm ² Copper	70mm ² Copper
1 x 240mm ² Aluminium (multi-core)	70mm ² Copper	70mm ² Copper	70mm ² Copper
2 x 240mm ² Aluminium (multi-core)	120mm ² Copper	120mm ² Copper	120mm ² Copper
3 x 240mm ² Aluminium (multi-core)	150mm ² Copper	150mm ² Copper	150mm ² Copper
1 x 300mm ² Aluminium (multi-core)	95mm ² Copper	95mm ² Copper	95mm ² Copper
2 x 300mm ² Aluminium (multi-core)	150mm ² Copper	150mm ² Copper	150mm ² Copper
3 x 300mm ² Aluminium (multi-core)	240mm ² Copper	240mm ² Copper	240mm ² Copper
4 x 300mm ² Aluminium or above (multi-core)	300mm ² Copper	300mm ² Copper	300mm ² Copper
4 x 300mm ² Copper (single core)	150mm ² Copper	150mm ² Copper	150mm ² Copper
8 x 300mm ² Copper (single core)	185mm ² Copper	185mm ² Copper	185mm ² Copper
4 x 500mm ² Copper (single core)	185mm ² Copper	185mm ² Copper	185mm ² Copper
4 x 630mm ² Copper (single core)	300mm ² Copper	300mm ² Copper	300mm ² Copper
8 x 500mm ² Copper (single core)	300mm ² Copper	300mm ² Copper	300mm ² Copper
8 x 630mm ² Copper (single core)	500mm ² Copper	500mm ² Copper	500mm ² Copper
16 x 500mm ² Copper (single core)	500mm ² Copper	500mm ² Copper	500mm ² Copper

TABLE 1. POE MEN LINK & MAIN EARTH CABLE SIZES

The 240mm² multi-core network cable is the standard cable currently used by Evoenergy for the majority of commercial installations subjected to site requirements and loads.

Please see an Evoenergy project officer for incoming cable size for POE cubicles that is serviced by Evoenergy network cables.

APPENDIX B – METHOD 1 SCHEMATIC

FIGURE 3. FREE STANDING POE CUBICLE SEPARATE TO THE MSB WITH TWO MEN LINKS AND TWO EARTH STAKES

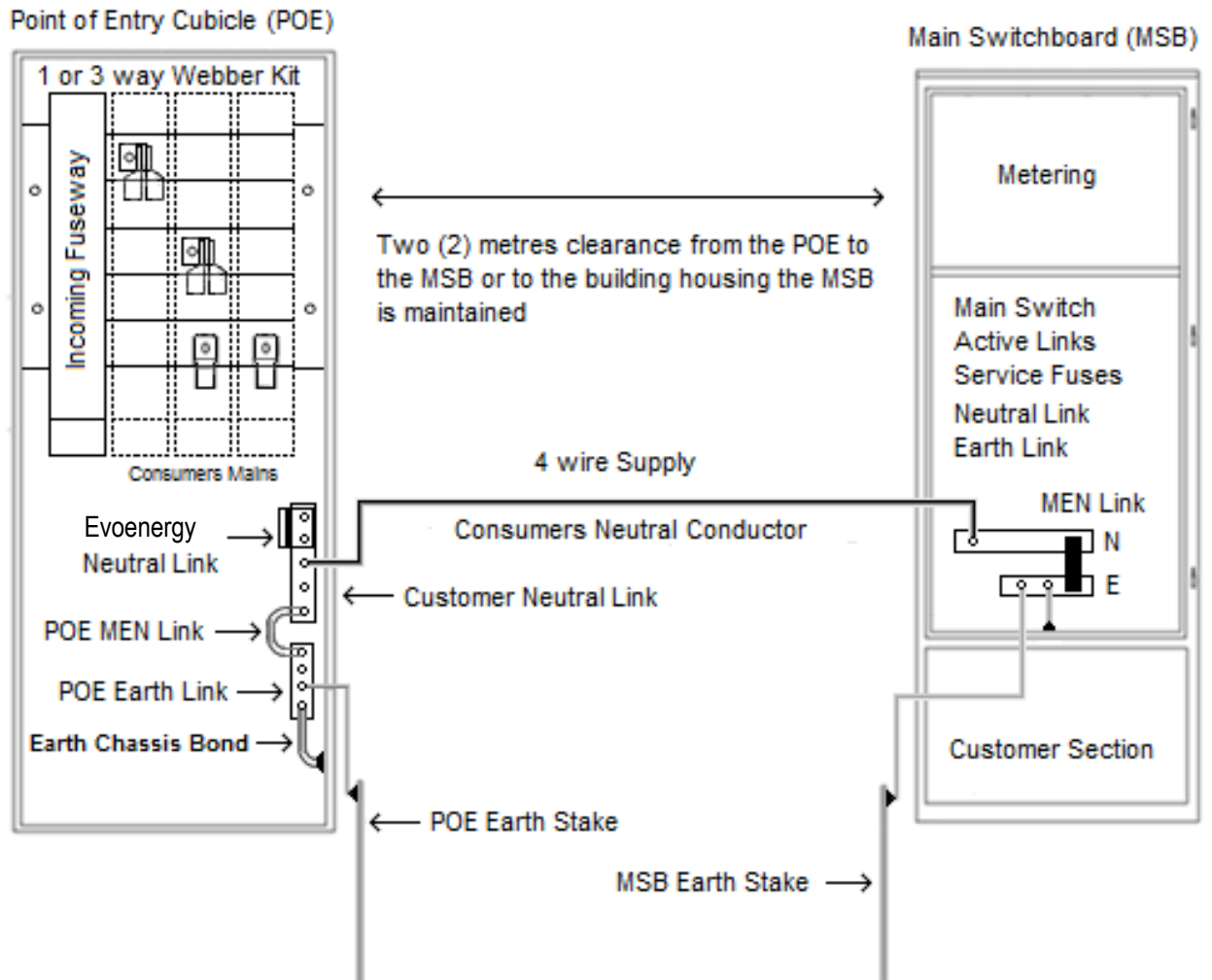

Note:

For accurate neutral / earth bar layouts refer to Evoenergy drawing 8913-213-06
 POE & MSB earth stake must comply with AS/NZS 3000

APPENDIX C – METHOD 2 SCHEMATIC

FIGURE 4. FREE STANDING POE CUBICLE WITH THE MAIN BUILDING MEN LINK AND MAIN BUILDING EARTH STAKE LOCATED AT THE POE BEHIND THE EVOENERGY LOCK

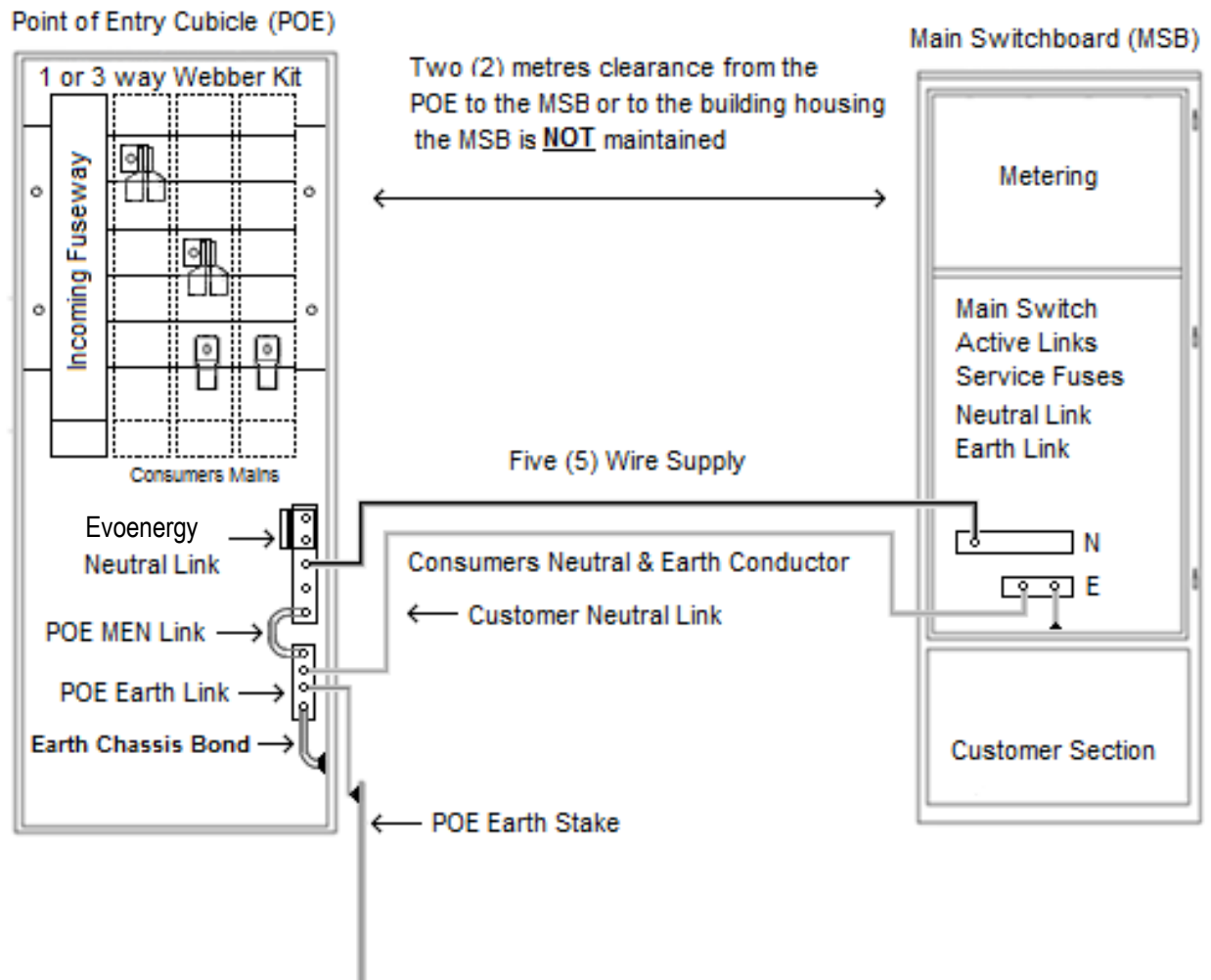

Note:

For accurate neutral / earth bar layouts refer to Evoenergy drawing 8913-213-06
 POE earth stake must comply with AS/NZS 3000

APPENDIX D – METHOD 3 SCHEMATIC

FIGURE 5. COMBINATION POE CUBICLE & MSB WITH NEUTRAL AND EARTH LINKS COMMON TO THE POE AND CUSTOMER CUBICLES, THE MEN CAN BE PERFORMED INSIDE THE CUSTOMER CUBICLE

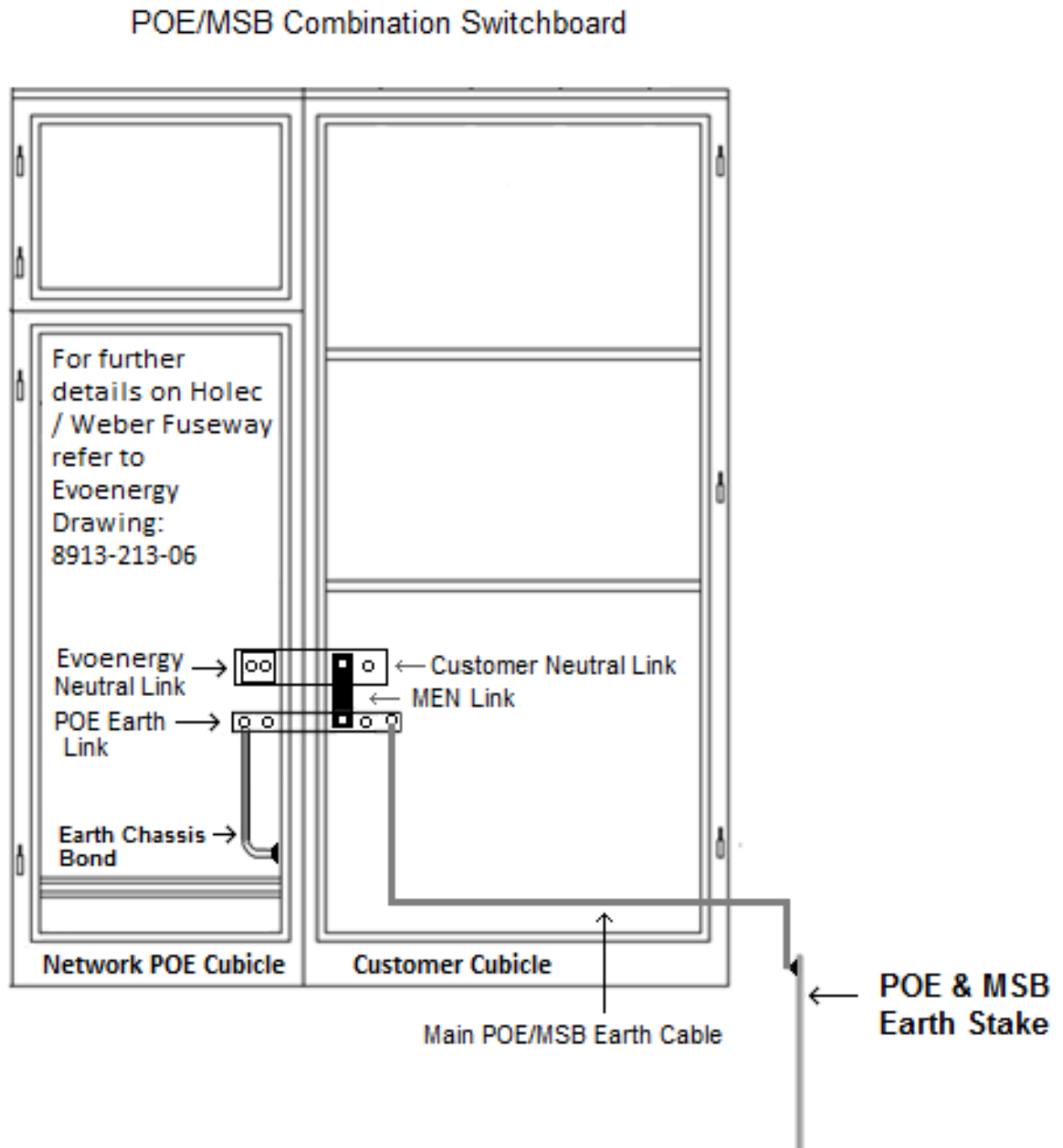

Note:

M.E.N. can be made in Customer's cubicle provided it is a common busbar arrangement within the POE/MSB; No joints or cable is permitted for M.EN

POE & MSB earth stake must comply with AS/NZS 3000

APPENDIX E – METHOD 4 SCHEMATIC

FIGURE 6. COMBINATION POE CUBICLE AND MSB CONTAINING SEPARATE NEUTRAL AND EARTH LINKS WITH THE MEN LINK AND THE MAIN EARTH CABLE TERMINATING INSIDE THE POE CUBICLE BEHIND THE EVOENERGY LOCK

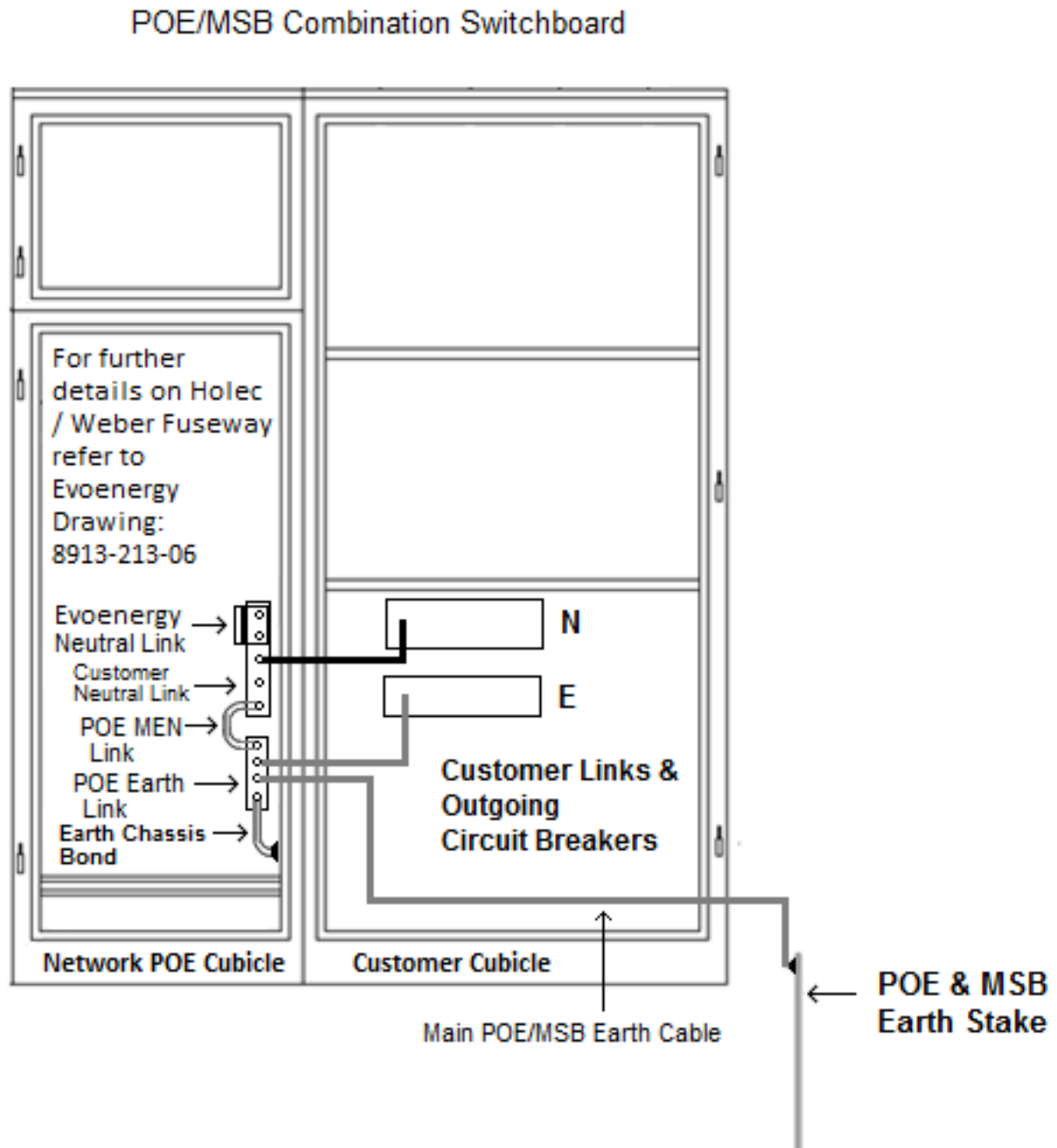

Note:

For accurate neutral / earth bar layouts refer to Evoenergy drawing 8913-213-06 to be updated
POE & MSB earth stake must comply with AS/NZS 3000